



Digital Camera &
Image Filing Software

TD-10 / EyeCAM

Serving Your Vision



Digital Camera & Image Filing Software

TD-10 / EyeCAM

User-friendly ultra-high resolution digital imaging system with USB 3.0 connection and DICOM compatibility, realized with simple operation in combination with TD-10 digital camera and EyeCAM image & video filing software

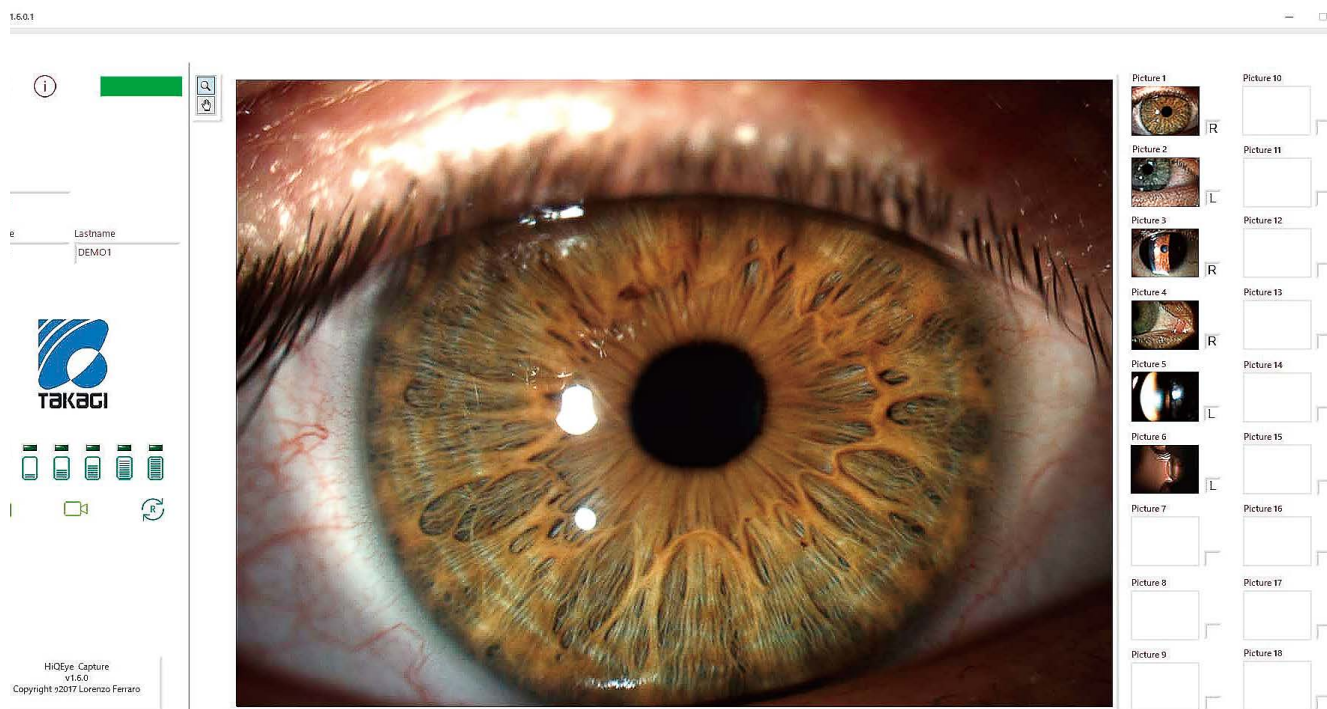

The captured images are created by inlay.

Use of ultra high resolution 10.7 mega pixel camera

Use of ultra high resolution 10.7 mega pixel camera with 3856 x 2764 picture size, delivering 7.4 times higher-resolution compared to the previous digital camera of TD-1plus.

USB 3.0 connection interface

By changing to the new USB 3.0 interface, data transfer speed is now approximately 6.4 times faster than that of the previous IEEE1394b fire-wire interface. Stress-free high-resolution live images are made possible with a high frame rate of 28 fps.

User friendly software with DICOM compatibility

User friendly software with patient database, full image editing facility, and DICOM compatibility.



Neat digital imaging system with hidden cables

In combination with our LED slit lamps minimum cables for TD-10 are exposed as they can be quickly and neatly concealed in the slit lamp's arm.



Yellow filter built-in as standard

High-contrast images are easily obtained by using the built-in yellow filter for corneal fluorescein observation. In conjunction with our slit lamp's cobalt blue filter even higher-contrast images can be achieved.

Capturing of still images with one push

In combination with our supplied trigger cable, still images can be captured instantly and conveniently by pressing the joystick button of the slit lamp. Captured images can be displayed as thumbnail images in the right part of the screen for evaluation.



New EyeCAM main screen design

The conventional image filing software & patient database have been further upgraded for more ease of use and intuitive handling by reviewing each icon while maintaining the convenient functionality.

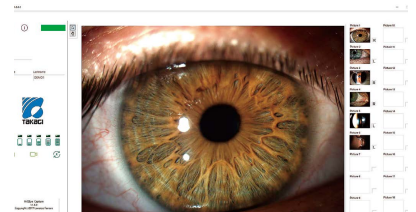

Easy capture with six pre-stored eye settings and automatic left/right eye detection

Setting of the digital camera can be changed and saved easily with six types of scene files according to the eye condition and image type required. Use our pre-saved recommended settings or simply adjust each pre-set to your own desired level for very fast and convenient high quality image acquisition.

A left or right eye can be automatically detected by moving the joystick to the right and left and saved with each captured image.



Convenient comparison functions for follow-up observations

The newly captured images and the images taken in past examinations can be displayed on the same screen. Up to six images can be displayed and compared at once.

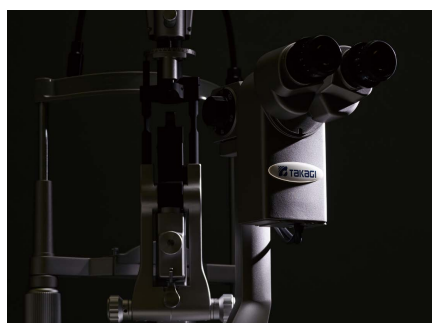

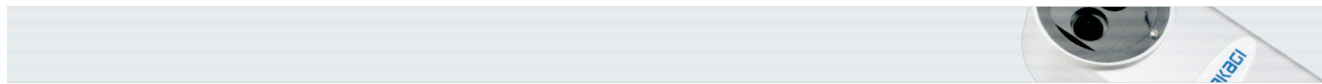

Camera Specifications

Picture size	3856 x 2764
Resolution depth	12 bit
Digital interface	USB 3.0
Frame rate	28 fps
Electricity consumption	Less than 4.5W

System Requirements

OS	Windows 7, 8, & 10 64bit (All Editions)
RAM	4GB or more recommended
Interface	Incorporated USB 3.0
CPU	Intel i5 or superior CPU recommended
Monitor resolution	Full HD (1920 x 1080)
Video board	Dedicated video board with more than GPU memory of 1GB

Dimensions

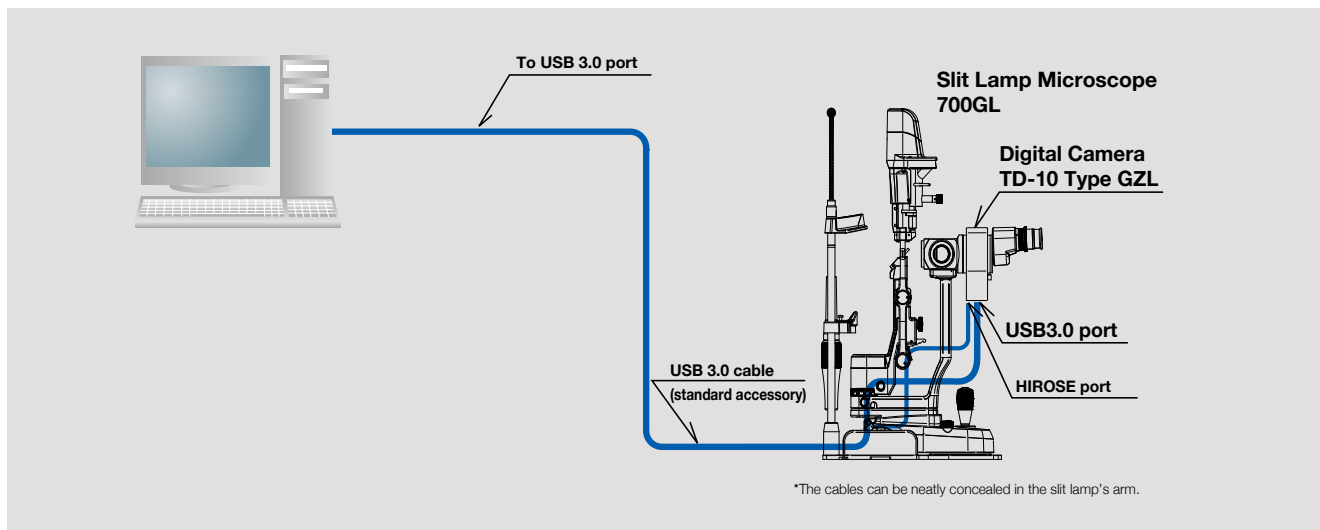
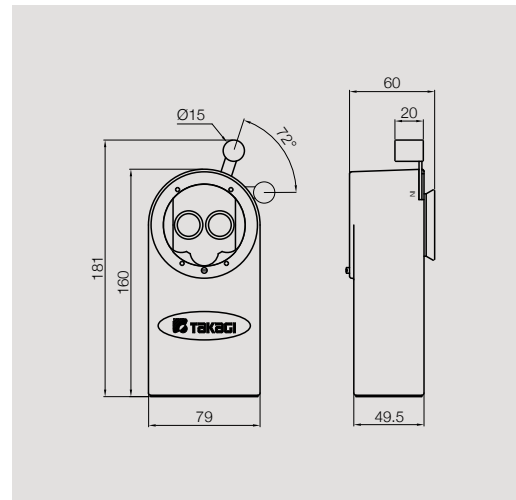

Combination with background illumination system

In combination with our background illumination device, a more comprehensive explanation is made possible to the patient.

* Background illumination built-in as standard with 700GL and 4ZL models

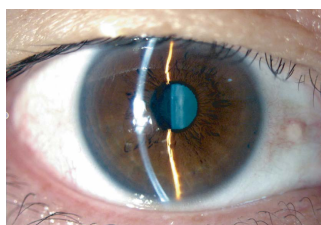

Slit lamp models compatible with TD-10 types

Compatible models	Type GZL	700GL, 2ZL, 4ZL

Caution To ensure safe and correct handling please read the user manual before using.

- Description and appearance as detailed in this catalogue may be subject to change as improvements are made to products.
- Colours as they appear in catalogue photographs may be slightly different to actual products due to lighting conditions when photographs were taken, or print colours.

TAKAGI SEIKO CO., LTD.
 330-2 Iwafune, Nakano-shi, Nagano-ken, 383-8585, Japan
 TEL : +81(0)269-22-4511(Switchboard) URL : <https://www.takagi-j.com>



Takagi Ophthalmic Instruments Europe Ltd
 Citylabs 1.0, Nelson Street, Manchester, M13 9NQ, UK
 TEL : +44 (0)161 273 6330 URL : <https://www.takagieurope.com>



Your local distributor

