



# Slit Lamp Microscope 30GL

*Serving Your Vision*



Slit Lamp Microscope

# 30GL

Greenough-style slit lamp provides peak optical performance and practicality



TAKAGI has been serving the vision of the global eye-care industry since 1955.

TAKAGI brand products are developed, designed and manufactured in Nagano, a region famed for its thriving precision manufacturing industry. Protecting eye health means protecting opportunities to see the beautiful things in the world. It is based on this belief that we take great joy and pride in making our instruments beautiful as well as functional. Our world-class technological capabilities, assured quality and outstanding service, make us trusted by ophthalmic professionals in more than 80 countries worldwide.

TAKAGI's slit lamps feature globally recognised technologies that are essential for high-quality eye care, including outstanding light source characteristics and reliable optics.

The unique design combines both style and usability, offering ease of operation and infection control.

The 30GL is simple and practical slit lamp ideal for routine examinations. Designed with both comfort and practicality in mind, it provides high-level performance in a wide range of examinations from cornea to retina. Featuring TAKAGI's latest LED technologies, the 30GL achieves a clear observation image with bright and sharp light and minimal colour and light irregularities. Its graceful form featuring a built-in cable (patented technology) is also easy to disinfect, making it effective in preventing infection.

# Optics

## High-performance Greenough-type microscope

Providing all the basic functions of a Greenough-type slit lamp, the 30GL is equipped with the highest-level optical performance, making it possible to observe all structures of the eye in fine detail. With two types of eyepieces (10x and 16x magnification) fitted as standard, a maximum 25x total magnification can be realised.

## Optical design ensures comfortable observation

The eyepiece unit with a binocular stereo angle of 13° convergence helps to realise easy fusion and stress-free observation. The maximum illumination field diameter of 14 mm, which is compatible not only with the average corneal diameter (approx. 12 mm), but also with soft contact lens (SCL) users, ensures both brightness and ease of observation.

By attaching an optional diffuser the diffusion of light makes it even easier to illuminate the entire eye and peripheral areas, further expanding the range of observation.

## Wide range of filters included as standard

As with other TAKAGI slit lamps, the 30GL comes with a wide range of filters included as standard.

The blue correction and blue cut filters protect patients' eyes from harmful light while leveraging the merits of LEDs. The blue filter is effective for fluorescein staining observations and the green (red-free) filter can be used for contrast enhancement, meaning that a diverse range of observations can be easily conducted. The blue correction filter also has the effect of producing a colour tone similar to that of a halogen lamp, while preventing harmful light damage.

## Latest TAKAGI LED technologies

The 30GL is designed specifically for LED light sources and provides a natural warm white colour similar to that of halogen and sharp slit illumination.

The lamp unit uses a specially designed LED light source, virtually eliminating all concerns about bulb replacement for the lifetime of the product.

## Uniform LED light source provides bright and sharp illumination

A single 1-element, high-luminance LED is used to realise a stable and uniform slit illumination by controlling the colour variations and irregularities inherent in LEDs. The bright and sharp light makes it possible to clearly see the details of hard-to-discern microstructures in the eye.

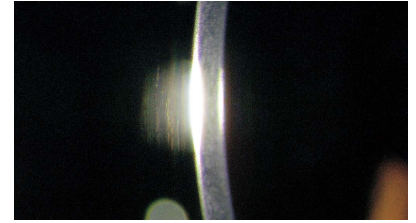

Bright and sharp LED light source\*

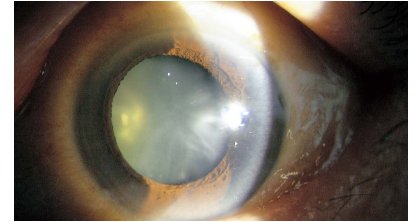
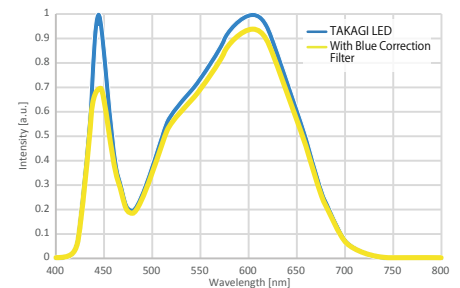

Image with blue correction filter in use\*

\*Images taken with a slit lamp using the same light sources.



With a wavelength peak at 450 nm, sharp slit illumination is realised

# Design

## Functional beauty that realises a safe, clean and comfortable examination environment

Adopting a ground-breaking design that keeps all cables, including power cables, out of sight and unexposed makes it possible to eliminate damage to cables caused by external factors, and so greatly reduces potential causes of failure.

The ST-50 Smart Table, which has no exposed mechanical parts, and the CR-750S Motorized Patient Chair, which can be raised and lowered using buttons on the ST-50, can be used together to enhance convenience, ensuring an examination environment that is safe, comfortable and exudes a sense of cleanliness.



Installation example for the ST-50 with a slit lamp from the same series (700GL)

# Usability

## Comfortable design based on ergonomics

The 30GL is a high-performance Greenough-type slit lamp based on an ergonomic design that aims to optimise the size and placement of various knobs in pursuit of comfortable operability.

It uses two magnifications, and the magnification can be easily changed by operating the magnification lever located under the binocular tubes. The light-intensity control knob makes it possible to continuously adjust light intensity. Using the joystick enables one-handed control with a lightness and smoothness of movement that does not place a burden on the wrists, fingers or arms. The headrest can be easily adjusted up and down, and the forehead rest features a finger rest, so that movement can be stabilised at the touch of a finger, making examinations easier.

## Practical options

For IOP measurement the R-type applanation tonometer AT-1 can be used together with a tonometer base designed specifically for the 30GL. Please use together with the S12-18 a reusable measuring prism that is environmentally friendly and economical.



## Specifications

Model name	30GL Slit Lamp Microscope	
Microscope	Type	Greenough stereoscopic binocular microscope
	Magnification changer	Revolver objective changing system with 2 magnification changes
	Eyepiece	10x / 16x
	Total magnifications	10x / 16x / 25x (25x when 16x eyepieces are in use)
	Field of view (diameter)	18 / 11.25 mm with 10x eye pieces, 15 / 9.3 mm with 16x eyepieces
	Stereo angle	13°
	Inter pupillary distance	52 - 82 mm
Illumination Unit	Eyepiece diopter range	±8D with 10x eye pieces, ±10D with 16x eyepieces
	Slit image width	Continuously variable 0-14 mm (almost circular at 14 mm)
	Slit image length	Continuously variable 0-14 mm with steps at 0.2 / 1 / 2 / 3 / 5 / 10 mm
	Slit image rotation	Continuously variable 0-180° with 3 click stops at 45° / 90° / 135°
	Slit decentration (horizontal)	Possible (fixable at 0°)
	Slit inclination (vertical)	0° / 5° / 10° / 15° / 20°
	Illumination field diameter	14 / 10 / 5 / 3 / 2 / 1 / 0.2 mm
Base Unit	Filters	Blue / Green (red-free) / Blue correction / Blue cut
	Light source	LED (3500K)
	Base unit operation	Single-handed joystick operation for forward-backward, left-right, up-down movement.
	Movement range	105 mm (forward-backward, left-right), 30 mm (up-down)
Headrest Unit	Fine movement range	15 mm (forward-backward, left-right)
	Vertical movement range	95 mm
Power Unit	Fixation light	LED (red)
	Power supply	AC100V - AC240V (±10%)
Weight (excluding power adapter and options)	Power input	DC5V 2A
		12.5 kg

## Dimensions

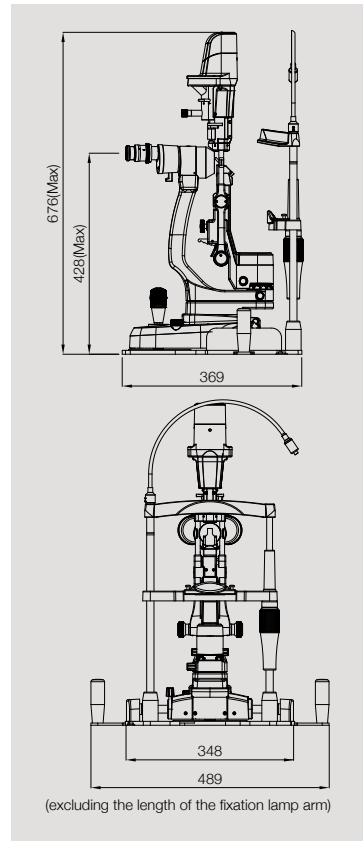

AT-1 installation example (Image shows installation on 700GL slit lamp in the same series)

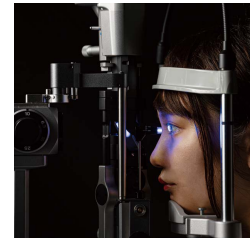

AT-1 in use (Image shows installation on 700GL slit lamp in the same series)

## System Chart

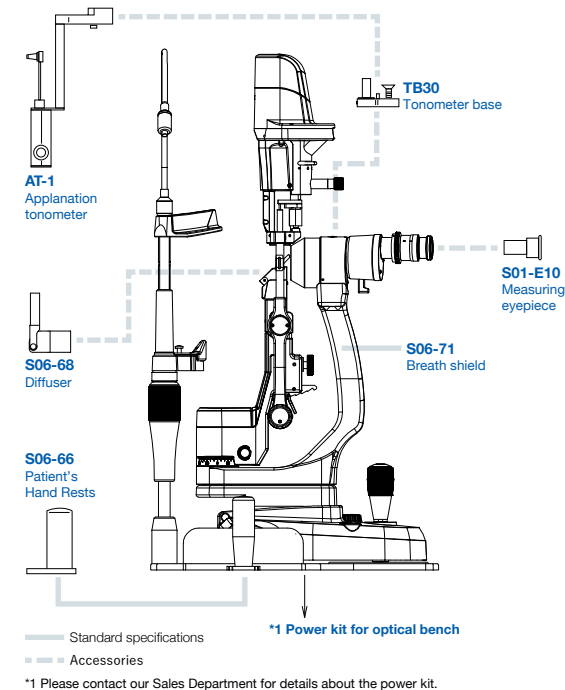

## Accessories

Model number	Detailed information
AT-1	Applanation tonometer R-type (requires a tonometer base for installation)
S01-E10	Eyepiece with scale for measuring
S06-66	Patient handrests so patient can grasp and comfortably maintain their posture during examinations (included as standard, available to purchase separately)
S06-68	Diffuses illumination, which is effective for observing the entire eye and peripheral areas of the eye at low magnification
S06-71	Breath shield (included as standard, available to purchase separately)
TB30	Tonometer base for AT-1

**Caution** To ensure safe and correct handling please read the user manual before using.

- Description and appearance as detailed in this brochure may be subject to change as improvements are made to products.
- Colours as they appear in brochure photographs may be slightly different to actual products due to lighting conditions when photographs were taken, or print colours.



For The Americas, Asia-Pacific & Middle East  
**TAKAGI SEIKO CO., LTD.**  
 330-2 Iwafune, Nakano-shi, Nagano-ken, 383-8585, Japan  
 TEL : +81(0)269-22-4511(Switchboard) URL : <https://www.takagi-j.com>



Your local distributor



For Europe & Africa  
**Takagi Ophthalmic Instruments Europe Ltd**  
 Citylabs 1.0, Nelson Street, Manchester, M13 9NQ, UK  
 TEL : +44 (0)161 273 6330 URL : <https://www.takagieurope.com>